

BANDIT

PRODUCT INFORMATION

2 QUART PRESSURE CUP

MODEL NO.

51-600 Single regulated

51-602 Double regulated

51-600A Agitated



THE BANDIT 2 QUART PRESSURE CUP
FEATURES A STAINLESS STEEL CLAMP BAND
WHICH PROVIDES 360 DEGREE CLAMP
PRESSURE BETWEEN THE LID AND CANNISTER



Coating Atomization Technologies

P.O.Box 17820
Boulder, CO 80301

303-438-5707

888-820-4498

FAX: 303-438-5708

ITEM NO.	PART NO.	DESCRIPTION	ITEM NO.	PART NO.	DESCRIPTION
1	51-634	CANNISTER ASSEMBLY	18	51-638	RELIEF VALVE CAP
2	51-611	BAND CLAMP ASSEMBLY	19	51-618	RELIEF VALVE SPRING
3	51-620-5	GASKET (5PACK)	20	51-631	RELIEF VALVE STEM
4	51-633	SPLASH GUARD	21	98-132	BALL
	51-657	SPLASH GUARD (Agitated)	22	51-617	PRESSURE RELIEF BODY
5	51-613	INNER LID	23	51-642	HANDLE ASSEMBLY
6	51-635E	OUTER LID		51-667	HANDLE ASSEMBLY (Agitated)
7	98-0119	9/16-18 LOCKNUT	24	98-8011	O-RING
8	51-632	SEAL PLATE	25	51-629	SEAL PLATE
9	98-8015	O-RING	26	98-0118	5/16-18 LOCKNUT
10	51-624	PRESSURE GAGE FITTING	27	98-0124	ACORN NUT
11	52-53 standard	PRESSURE GAGE (0 TO 15 psi)	28	51-616	REGULATOR ASSEMBLY
	52-52 optional*	PRESSURE GAGE (0 TO 60 psi)	29	51-636	CHECK POPPET
12	98-0120	5/8-18 LOCKNUT	30	51-619	SPRING
13	51-628	SEAL PLATE	31	51-643	RETAINING CAP
14	98-8016	O-RING	32	51-630	RELIEF VALVE ASSEMBLY
15	51-625	FLUID OUTLET ASSEMBLY	33	51-644	SPACER (15 psi regulator)
16	53-555	FLUID OUTLET NIPPLE			
17	51-623	PULL RING			
Not Shown	51-222	REGULATOR**	Not Shown	51-637-12	PLASTIC LINER (12 PACK)
ADDITIONAL PARTS FOR AGITATED VERSION 51-650A ONLY (51-670 AGITATOR SUB-ASSEMBLY)					
34	51-658	SLASH GUARD RETAINER	45	51-656	SEAL SPRING
35	51-647	AIR MOTOR	46	51-655	UPPER SHAFT GUIDE
36	98-182	ELBOW FITTING	47	98-8010	O-RING, TEFLON
37	51-663	HOSE ASSEMBLY	48	51-654	LOWER SHAFT GUIDE
38	51-669	DUAL REGULATOR ASSEMBLY	49	51-651	AGITATOR SHAFT
39	51-660	MUFFLER PACKING	50	51-653	SEAL HOUSING
40	51-665	MUFFLER ASSEMBLY	51	51-659	SLINGER RING
41	98-126	SET SCREW	52	98-179	SET SCREW
42	51-650	MOTOR BASE	53	51-648	IMPELLER
43	51-652	SHAFT COUPLING	54	51-649	IMPELLER SLEEVE
44	98-178	SET SCREW	55	51-671	SPLASH GUARD SPACER
Not Shown	10-5	REGULATOR REPAIR KIT			
Not Shown	10-120	AIR MOTOR REBUILD KIT	Note: Air motor performance is not guaranteed after field repair. Factory repair of air motor is recommended for best results.		
Not Shown	10-121	SHAFT SEAL & BEARING KIT			

*To convert unit to 0-50 psi, remove item 33 and replace pressure gage with P/N 52-52

** Second regulator to convert unit to double regulated



Coating Atomization Technologies

P.O.Box 17820
Boulder, CO 80301

303-438-5707
888-820-4498
FAX: 303-438-5708

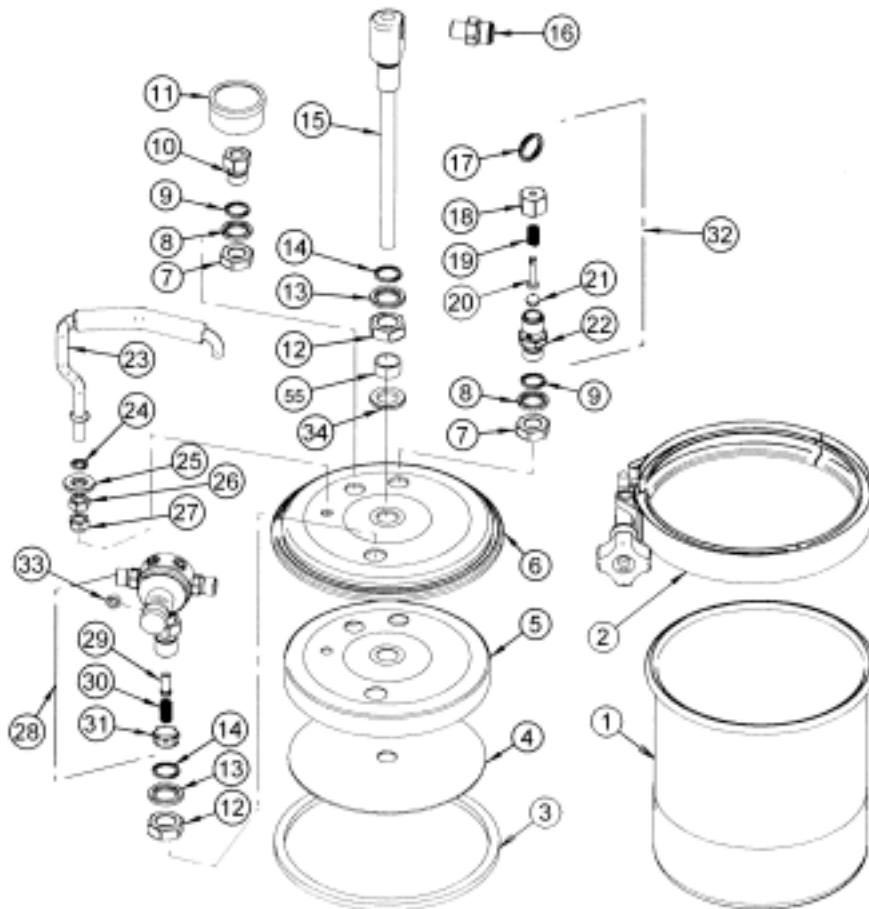

51-600 Bandit Pressure Cup Assembly

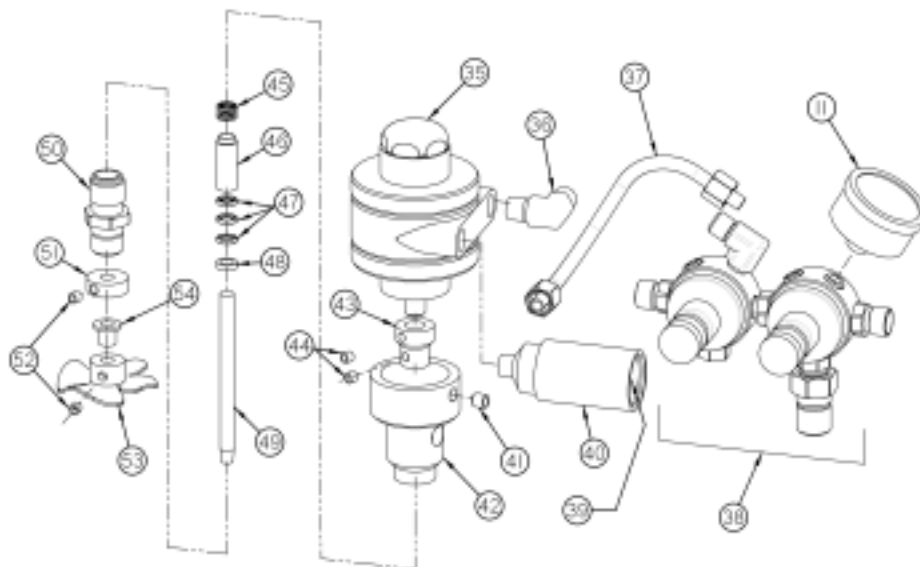

51-670 Bandit agitator sub-assembly

WARNING! MAX. WORKING PRESSURE 50 PSI

REMOVING THE LID

COMPLETELY RELIEVE PRESSURE IN CANISTER BEFORE ATTEMPTING TO REMOVE THE LID!

Loosen the clamp knob completely until it stops.

(By holding the clamp ends together with one hand the knob can be loosened to the stop rapidly.)

Disengage the T-bolt from one end of the clamp, spread the clamp only as much as necessary to clear the lid and lower clamp down around the cannister.

INSTALLING LID AND CLAMP

Place lid assembly on cannister; it is self centering with the cannister.

With the T-bolt disengaged, spread the clamp and place into position from above the lid.

Engage the T-bolt into the end of the clamp and tighten the knob. (By drawing the clamp ends together with one hand, the knob can be advanced rapidly before final tightening.)



Coating Atomization Technologies

P.O.Box 17820
Boulder, CO 80301

303-438-5707
888-820-4498
FAX: 303-438-5708